



# Universal Bracket System Spoke Arm Bracket



## PROJECT INFORMATION

|                |                   |
|----------------|-------------------|
| JOB NAME       |                   |
| FIXTURE TYPE   | Spoke Arm Bracket |
| CATALOG NUMBER |                   |
| APPROVED BY    |                   |

## SPECIFICATIONS

### Construction:

- Aluminum
- For use with 1.5" - 3.0" diameter spoke arms

### Overall Height:

- 5.50" (13.97 cm)

### Overall Width:

- 4.00" (10.16 cm)

### Overall Depth:

- 4.00" (10.16 cm)

### Warranty:

- Five-year limited warranty

**Note: Factory Installed Only**



## DIMENSIONS

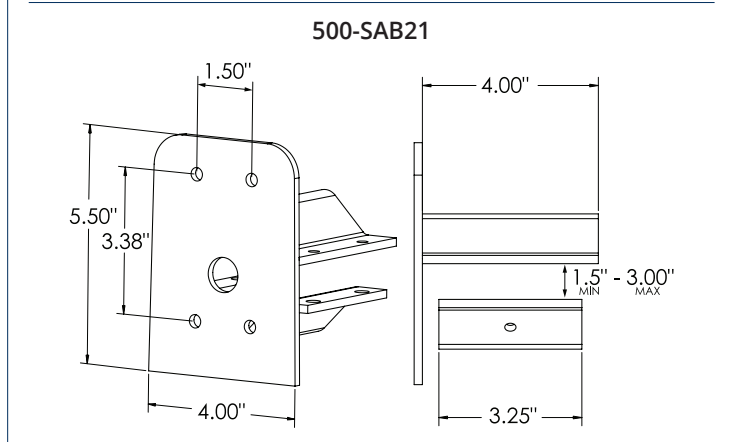
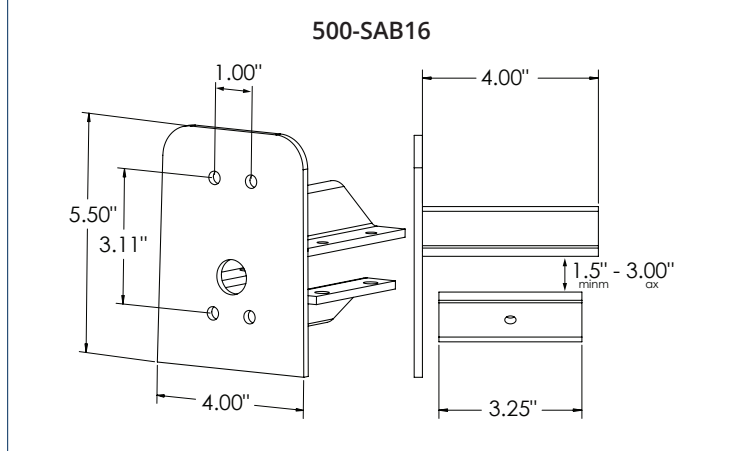

## ORDERING INFORMATION

| CATALOG # | DESCRIPTION                   | FINISH |
|-----------|-------------------------------|--------|
| 500-SAB16 | Spoke Arm Bracket for SLP 16" | Bronze |
| 500-SAB21 | Spoke Arm Bracket for SLP 22" | Bronze |