



Screw In Twist Lock Adapter



PROJECT INFORMATION

JOB NAME	
FIXTURE TYPE	Screw In Twist Lock Adapter
CATALOG NUMBER	TLRA-7P
APPROVED BY	

SPECIFICATIONS

Construction:

- Die Cast Aluminum

Weight:

- 0.4 lbs. / 0.181 kg.

Overall Height:

- 2.38" (6.0452 cm)

Overall Diameter:

- 2.60" (6.604 cm)

Warranty:

- Five-year limited warranty



DIMENSIONS

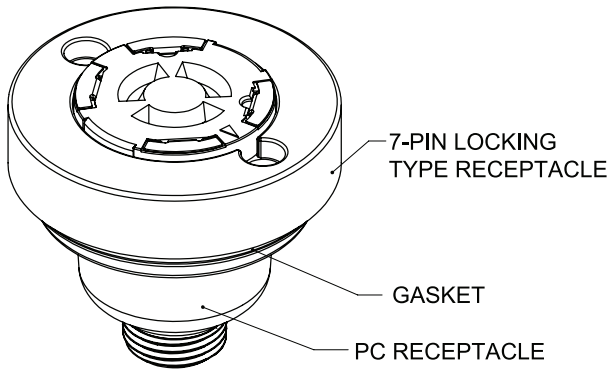
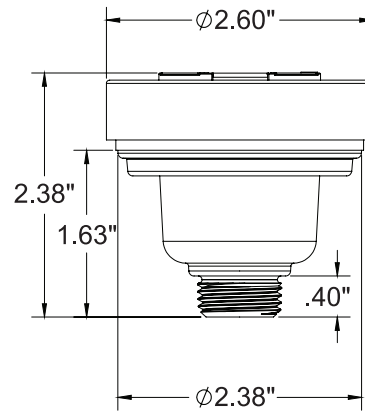

ORDERING INFORMATION

CATALOG #	DESCRIPTION	FINISH
TLRA-7P	Screw In Twist Lock Adapter	Bronze